

© This drawing may without our consent neither duplicated, still third persons submitted or handed over. Offences can after §18 of the Law over mean competition criminal pursuit to involve.

Ausgedruckte Zeichnung unterliegt nicht dem Änderungsdienst!
Printed Drawing is not automatically updated!

© Diese Zeichnung darf ohne unsere Einwilligung weder vervielfältigt, noch dritten Personen vorgelegt oder ausgenündigt werden. Zuwiderhandlungen können nach §18 des Gesetzes über unlauteren Wettbewerb strafrechtliche Verfolgung nach sich ziehen

1

2

3

4

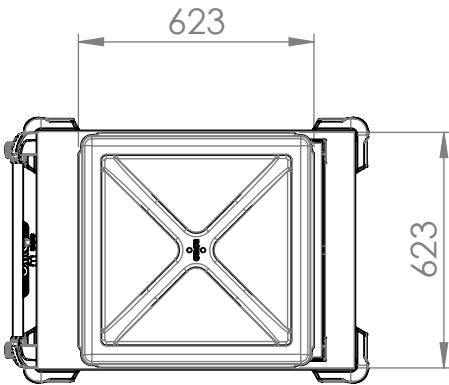
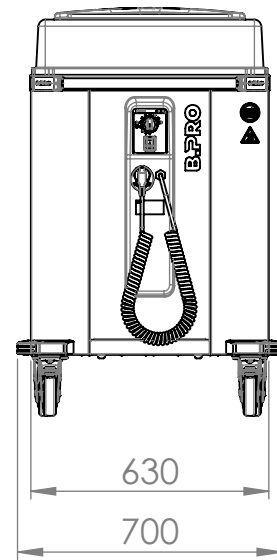
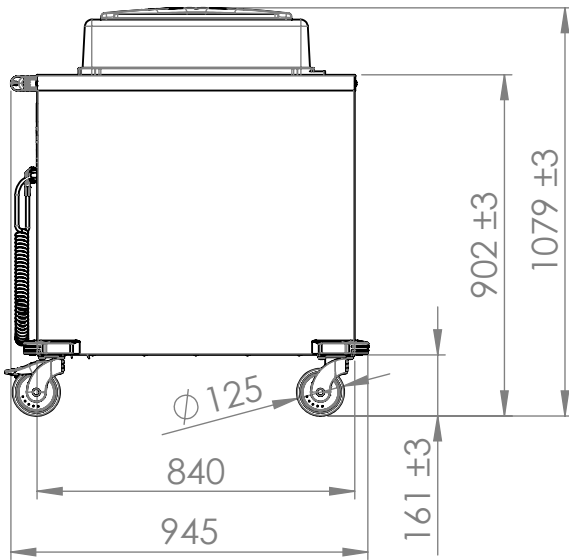

Stacking height:
=> with cover: 680mm
=> without cover: 540mm

Platform dimension: 581 mm x 581 mm

Max. load capacity: 200kg
Castors: synthetic

Power: 1,8kW
Electric connection: 220-240V/ 50-60Hz

Net weight: about 91kg

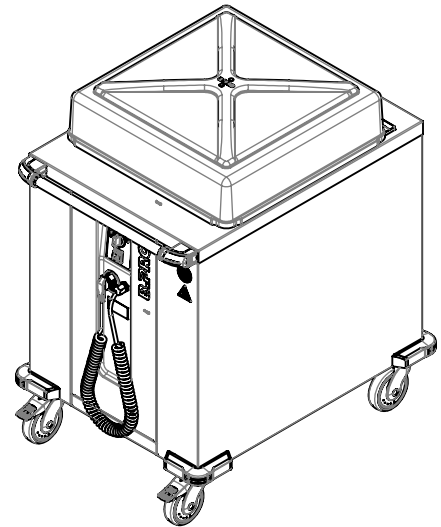

1	322.076.21										
Index	Rev.-No.	Description of modification							Date	Name	
B.PRO		Scale	M 1:20	Group	100	Status	freigegeben	Document type	KDI	Std. paper-size	A4
				Material				Surface			
Tolerances according to ISO 2768-cL		Date		Name		Document item-no.					
		Drawn		17.11.2021 SüßmannH		2000254719.05					
		Checked		17.11.2021 SüßmannH		SAP material-no.					
		Approved		17.11.2021 SüßmannH		00574910					
Origin		Description									
		UNI-H 58/58									

Notice: 2000253157 Sheet 1 of 1